

Product information

Drummotors

**TM 160-25**



*Van der Graaf*  
Power Transmission Equipment

[www.vandergraafpte.nl](http://www.vandergraafpte.nl)

# The TM 160's



playground



# TM 160-25



## A wide range of applications

Van der Graaf has achieved a prominent position on both the domestic and international market with its "GV" Drummotors.

The "GV" Drummotor has found success in a wide range of applications including the following: automotive, X-ray, construction, postal, courier, mining, aggregate, airline baggage, package flow, tyre manufacturing, fish processing, poultry processing, meat processing, agriculture, fruit and vegetable, farming, forestry, baking, dairy and many more.

4	Introduction
5	Selection table
6	Selection table Dahlander motors
7	Dimensions Drummotors mild steel
8	Dimensions Drummotors stainless steel
9	Dimensions Taildrums mild steel
10	Dimensions Taildrums stainless steel
11	Dimensions bracket
12	Cable exit
13	Cross sectional / parts description
15	Options
18	Product range
19	Notes
20	Contact us



## Selection table

TYPE TM 160.25	Power kW	Beltspeed m/s at 50 Hz							Min. L mm Design A	Min. L mm Design B	Full load curr. 400 V - 50 Hz I = ... A	Weight kg L=350
		Beltpull N										
210 Z	0,75	3,30 215	2,50 285	2,20 325					300	350	1,4	25
410 Z	0,75	1,70 420	1,25 570	1,10 650	0,80 890	0,65 1095			300	350	1,9	25
275 Z	0,55	3,30 160	2,50 210	2,20 240	1,60 325	0,95 550			300	300	1,1	23
475 Z	0,55	1,70 305	1,25 420	1,10 475	0,80 655	0,65 805	0,50 1045		300	300	1,3	23
405 Z	0,37	1,70 205	1,25 280	1,10 320	0,80 440	0,65 540	0,50 705	0,40 880	300	300	1,0	22
605 Z	0,37	0,31 1135							300	300	1,1	23
434 Z	0,25	1,70 140	1,25 190	1,10 215	0,80 295	0,65 365	0,50 475	0,40 595	300	300	0,7	21
834 Z	0,25	0,31 765	0,25 950	0,20 1190					300	300	1,0	23
825 Z	0,18	0,31 550	0,25 685	0,20 855					300	300	0,8	22
818 Z	0,13	0,31 400	0,25 495	0,20 620					300	300	0,6	21
1218 Z	0,13	0,15 825	0,13 950						300	350	0,9	25
1213 Z	0,10	0,15 635	0,13 730						300	300	0,6	23

Available standard facewidth's: 300 - 350 - 400 - 425 - 450 - 500 - 550 - 600 - 650 - 700 - 750 - 800 - 850 - 900 - 950 - 1000 mm

When an electro-mechanical brake is fitted, the minimum facewidth is increased by 75 mm

The total weight of a Drummotor grows approx. 2,5 kg per 100 mm

Available torque: (Beltpull N x drum diameter m) / 2 Nm

## Selection table Dahlander motors

TYPE TM 160.25	Power kW	Beltspeed m/s at 50 Hz						Min. L mm Design A	Min. L mm Design B	Full load curr. 400 V - 50 Hz I = ... A	Weight kg L=350
		Beltpull N									
<b>475/210 Z</b>	<b>0,55/0,75</b>	<b>1,70/3,40</b> 305/210	<b>1,25/2,50</b> 420/285	<b>1,10/2,20</b> 475/325	<b>0,80/1,60</b> 655/445	<b>0,65/1,30</b> 805/550	<b>0,50/1,00</b> 1045/715	300	350	1,4/1,7	25
<b>437/275 Z</b>	<b>0,27/0,55</b>	<b>1,70/3,40</b> 150	<b>1,25/2,50</b> 205	<b>1,10/2,20</b> 235	<b>0,80/1,60</b> 325	<b>0,65/1,30</b> 400	<b>0,50/1,00</b> 515 <b>0,40/0,80</b> 645	300	300	0,9/1,3	23
<b>825/405 Z</b>	<b>0,18/0,37</b>	<b>0,40/0,80</b> 435	<b>0,31/0,62</b> 565	<b>0,25/0,50</b> 695	<b>0,20/0,40</b> 870			300	300	1,0/0,9	23

Available standard facewidth's: 300 - 350 - 400 - 425 - 450 - 500 - 550 - 600 - 650 - 700 - 750 - 800 - 850 - 900 - 950 - 1000 mm

When an electro-mechanical brake is fitted, the minimum facewidth is increased by 75 mm

The total weight of a Drummotor grows approx. 2,5 kg per 100 mm

Available torque: (Beltpull N x drum diameter m) / 2 Nm



## Dimensions Drummotors mild steel

### TM 160A25

TM 160A25, mild steel Drummotor with cast iron junctionbox

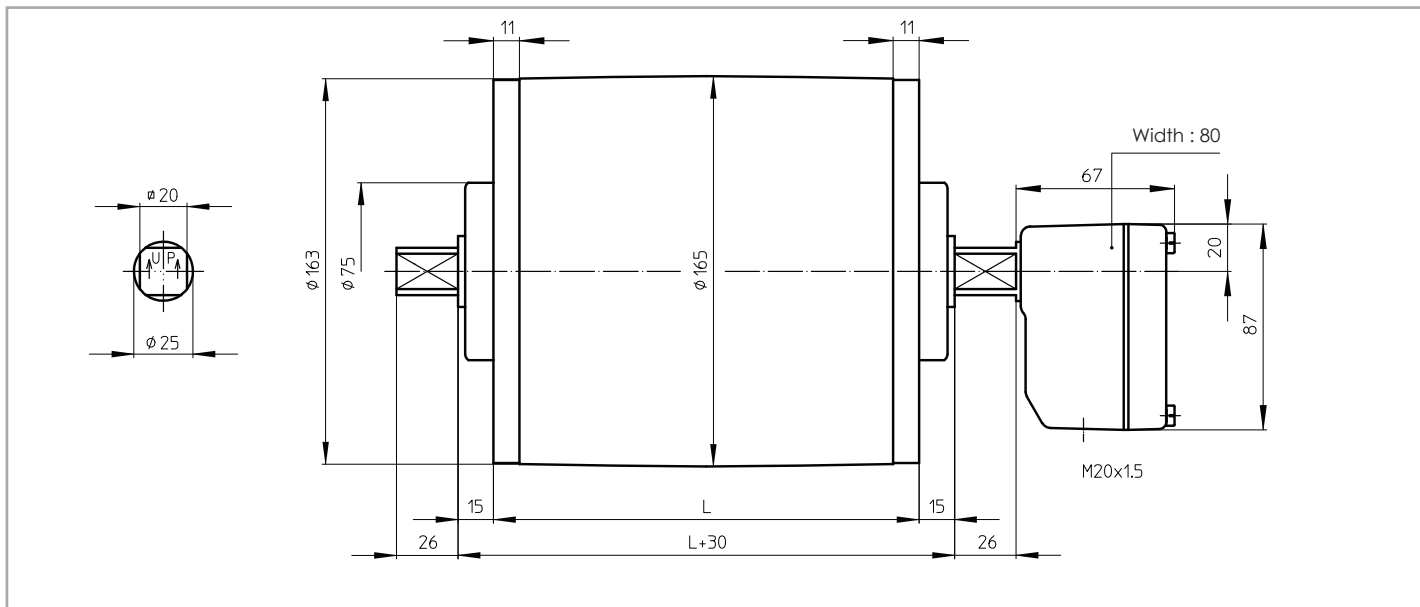

### TM 160B25

TM 160B25, mild steel Drummotor with cast iron junctionbox

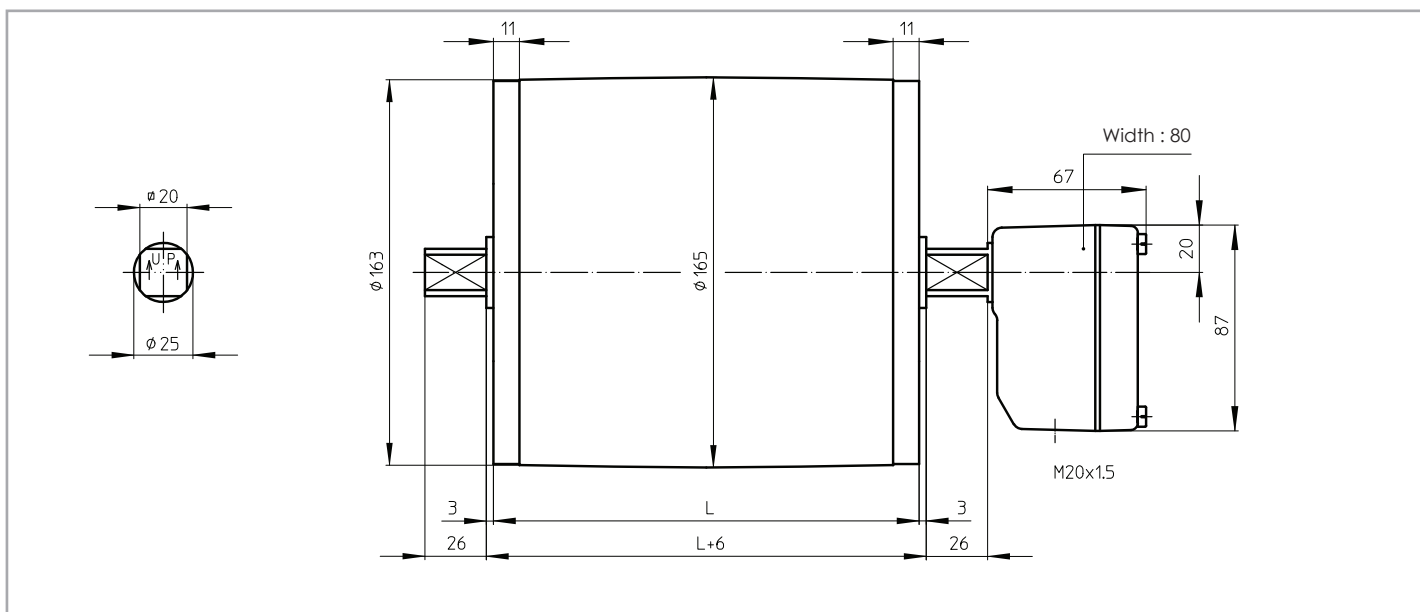

# Dimensions Drummotors stainless steel

## TM 160A25 CR

TM 160A25 CR, stainless steel Drummotor with polyamide junctionbox and CR sealing

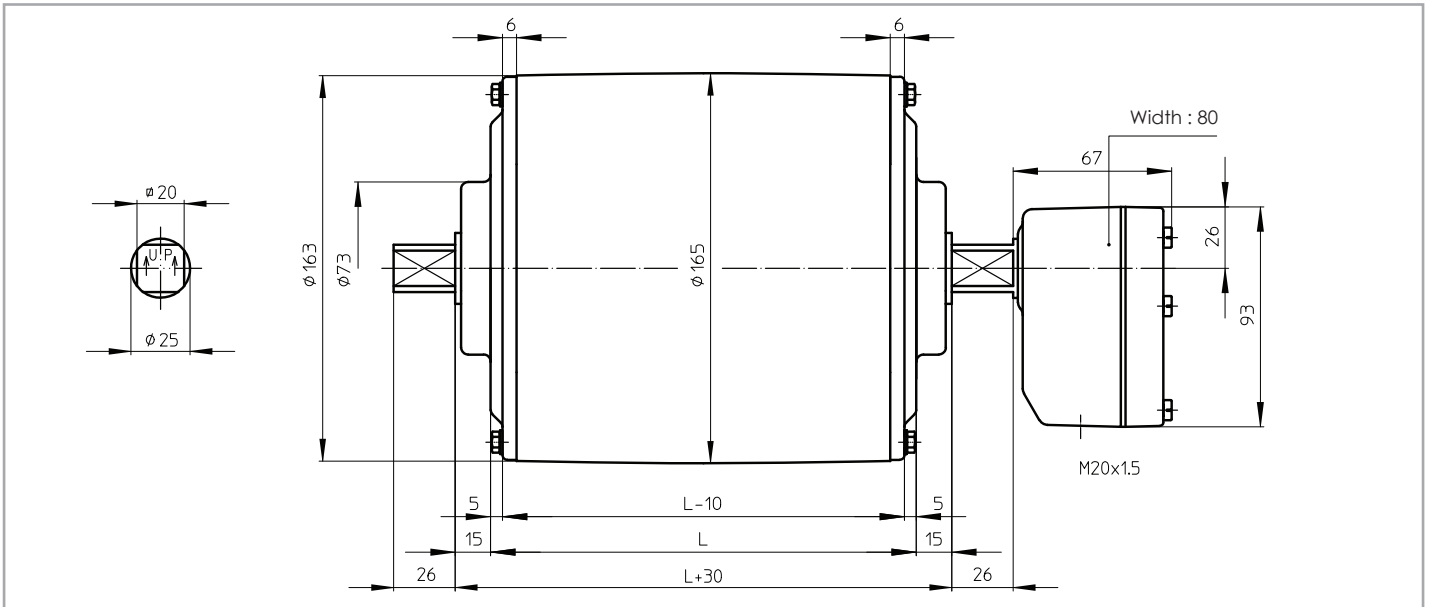

## TM 160B25 CR

TM 160B25 CR, stainless steel Drummotor with polyamide junctionbox and CR sealing

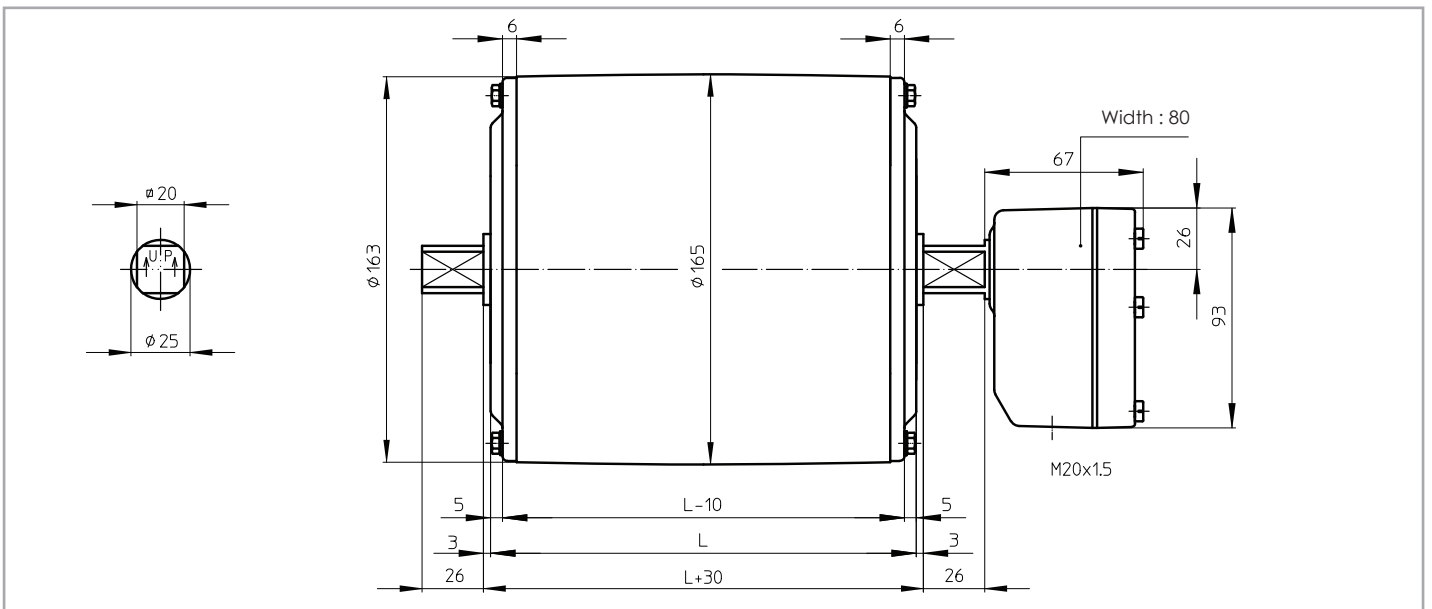





# Dimensions Taildrums mild steel

## KT 160A25

KT 160A25, mild steel Taildrum

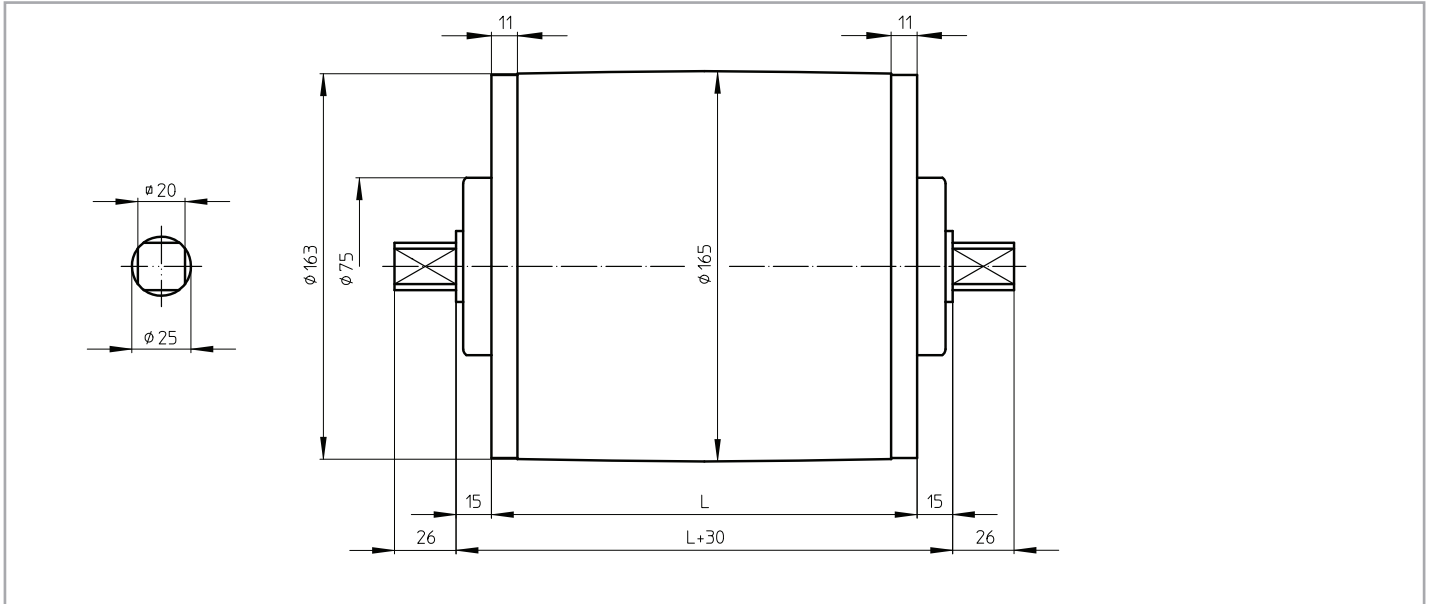

## KT 160B25

KT 160B25, mild steel Taildrum

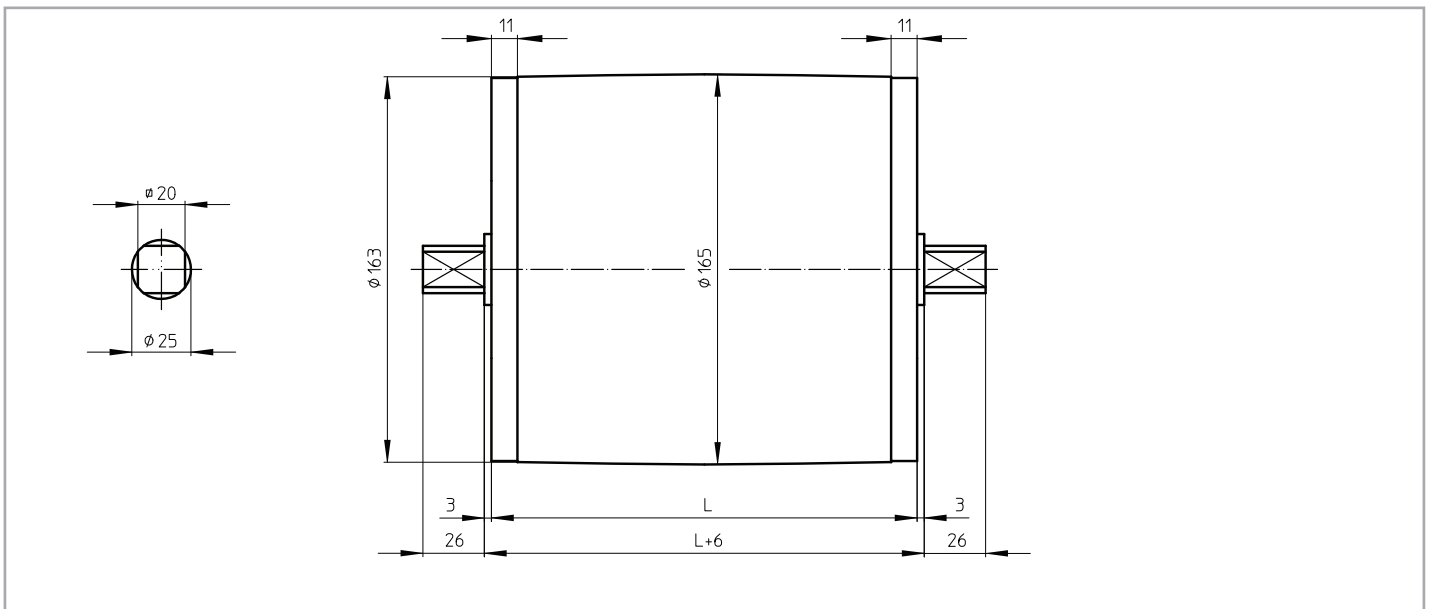

# Dimensions Taildrums stainless steel

## KT 160A25 CR

KT 160A25 CR, stainless steel Taildrum with CR sealing

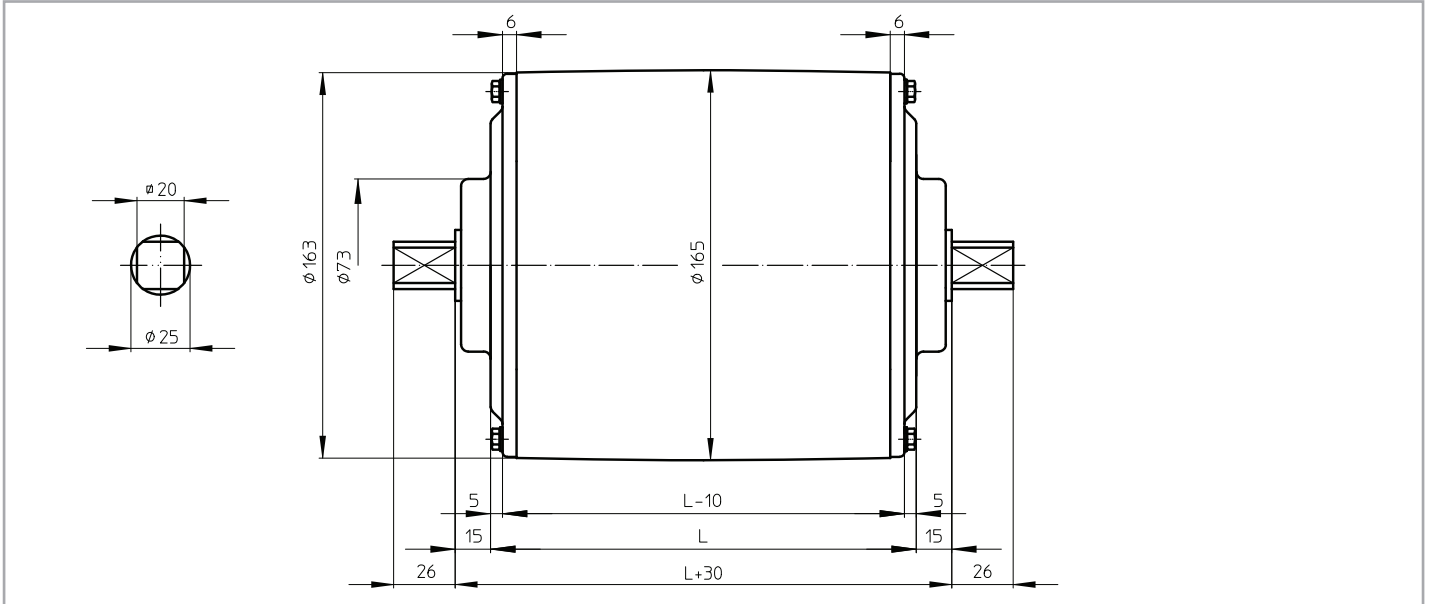

## KT 160B25 CR

KT 160B25 CR, stainless steel Taildrum with CR sealing

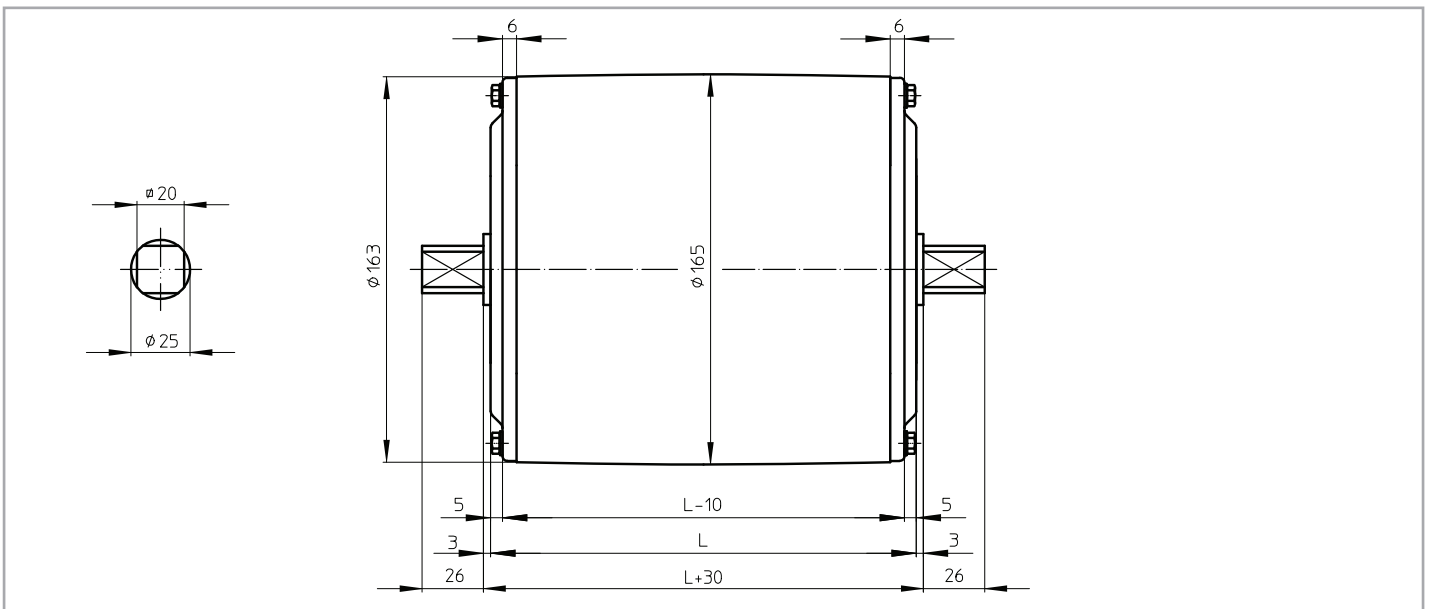



## Dimensions bracket

### AB 25

AB 25, cast iron or stainless steel bracket

Weight: 1,2 kg per pair

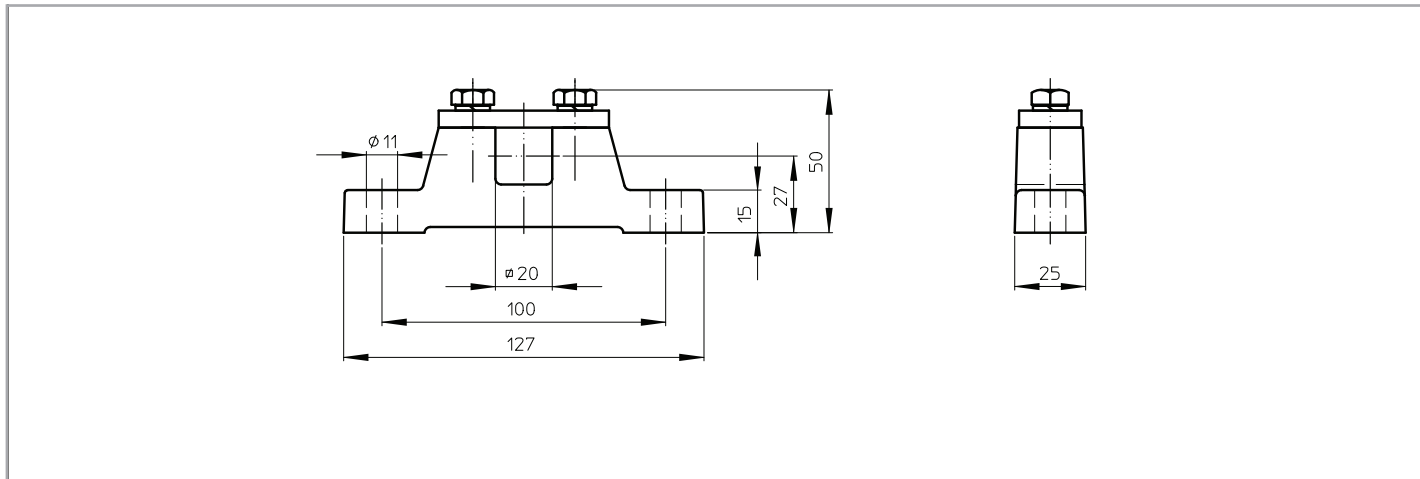

# Cable exit

Standard design of a TM 160-25 is with a cast iron junctionbox. For stainless steel design, this can be either a polyamide or stainless steel junctionbox.

On request a Drummotor can be fitted with a cable. In this case it is important to know the available voltage (preferably 1 voltage), the length of the cable, whether the cable is shielded or not and the type of cable exit. An overview of available cable exits is shown below.

## Option 1

Straight cable exit with cable gland

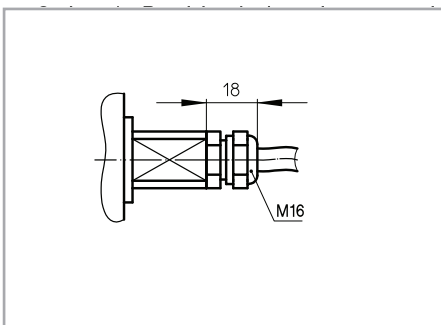

## Option 3

Elbow cable exit with cable gland  
(minimum facewidth increases with 25 mm)

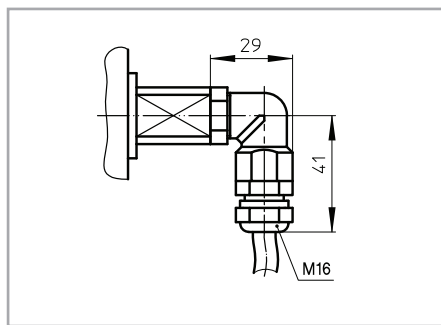

## Option 4

Open cable exit (minimum facewidth increases with 25 mm)

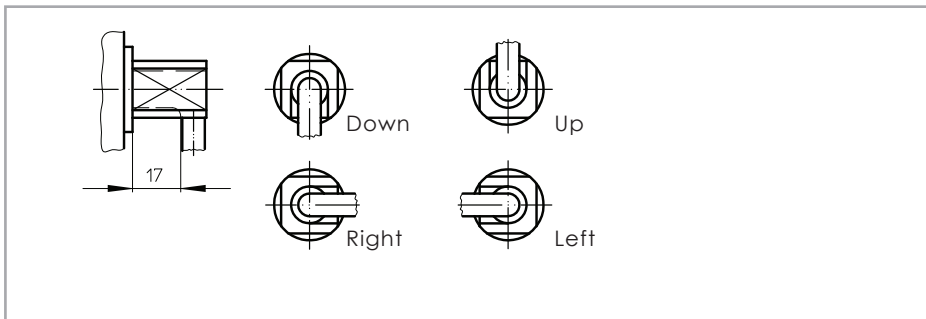



TM 160A25 Z

Legenda

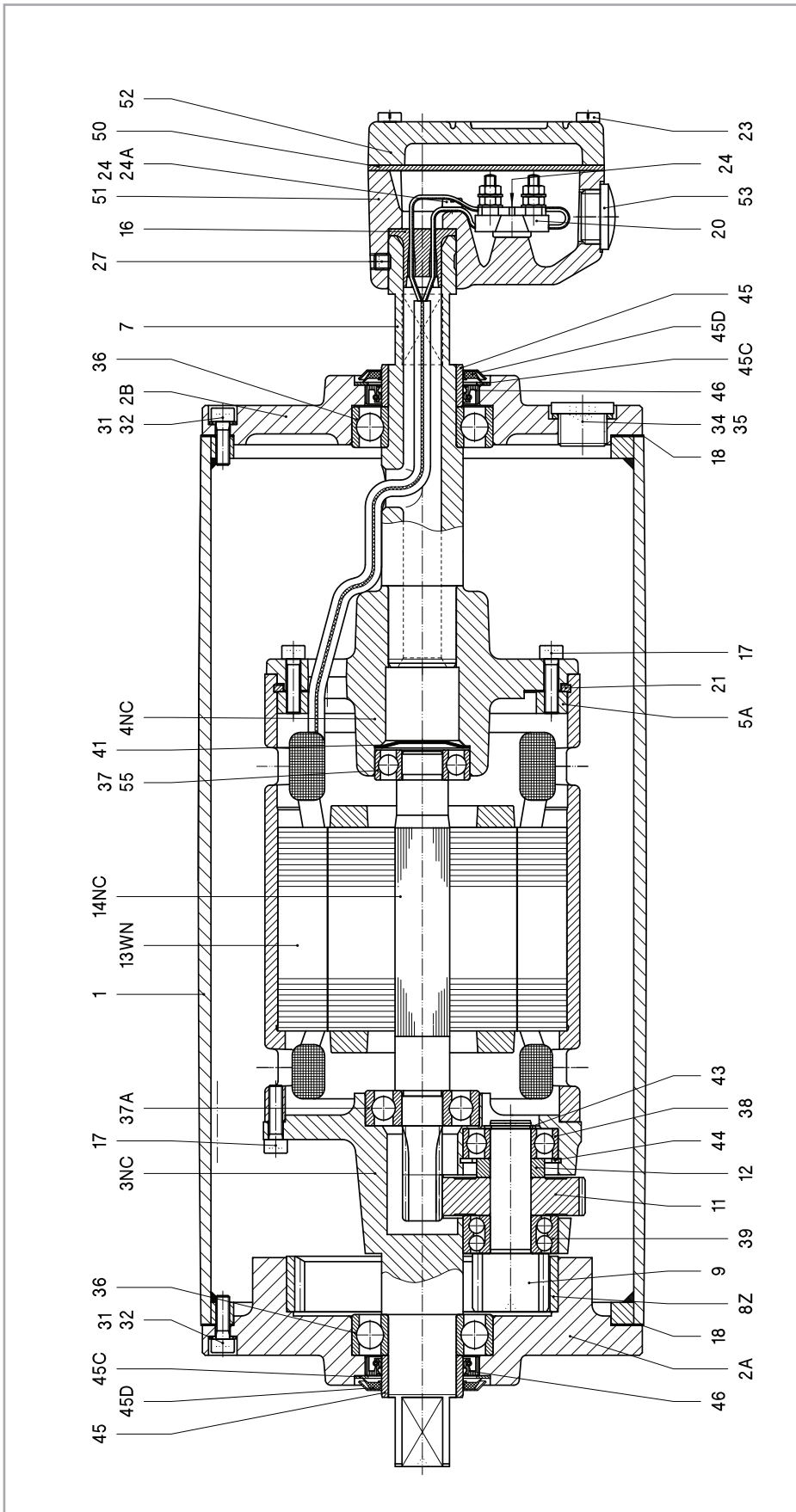

Remark: Drummotor also available in B-design (TM160B25 Z)

1	Shell	11	Gear	37	Ballbearing	45D	Gammaring
2A	Endflange	12	Distance ring	37A	Ballbearing	46	Oilseal
2B	Endflange	13WN	Stator	38	Ballbearing	50	Seal
3NC	Gearhousing	14NC	Rotor	39	Double-row ballbearing	51	Junctionbox
4NC	Motorflange	16	Cable passage	41	Locking disc	52	Junctionbox cover
5A	Mountingring	17	Int. hex screw	43	Circlip	53	Stopping plug
7	Hollow shaft	18	Gasket	44	Circlip	55	Ballbearing incl. backstop
8Z	Internal gear	20	Terminalboard	45	Bearing race	57	Dataplate
9	Pinion	21	Springring	45C	Shim plated		
		23	Cyl. head screw				
		24	Cyl. head screw				
		24A	Toothed lock washer				
		27	Setscrew				
		31	Int. hex screw				
		32	Washer				
		34	Fillerplug				
		35	Washer				
		36	Ballbearing				
		37					
		37A					
		38					
		39					
		41					
		43					
		44					
		45					
		45C					
		46					
		46D					
		50					
		51					
		52					
		53					
		55					

KT 160A25

Legenda

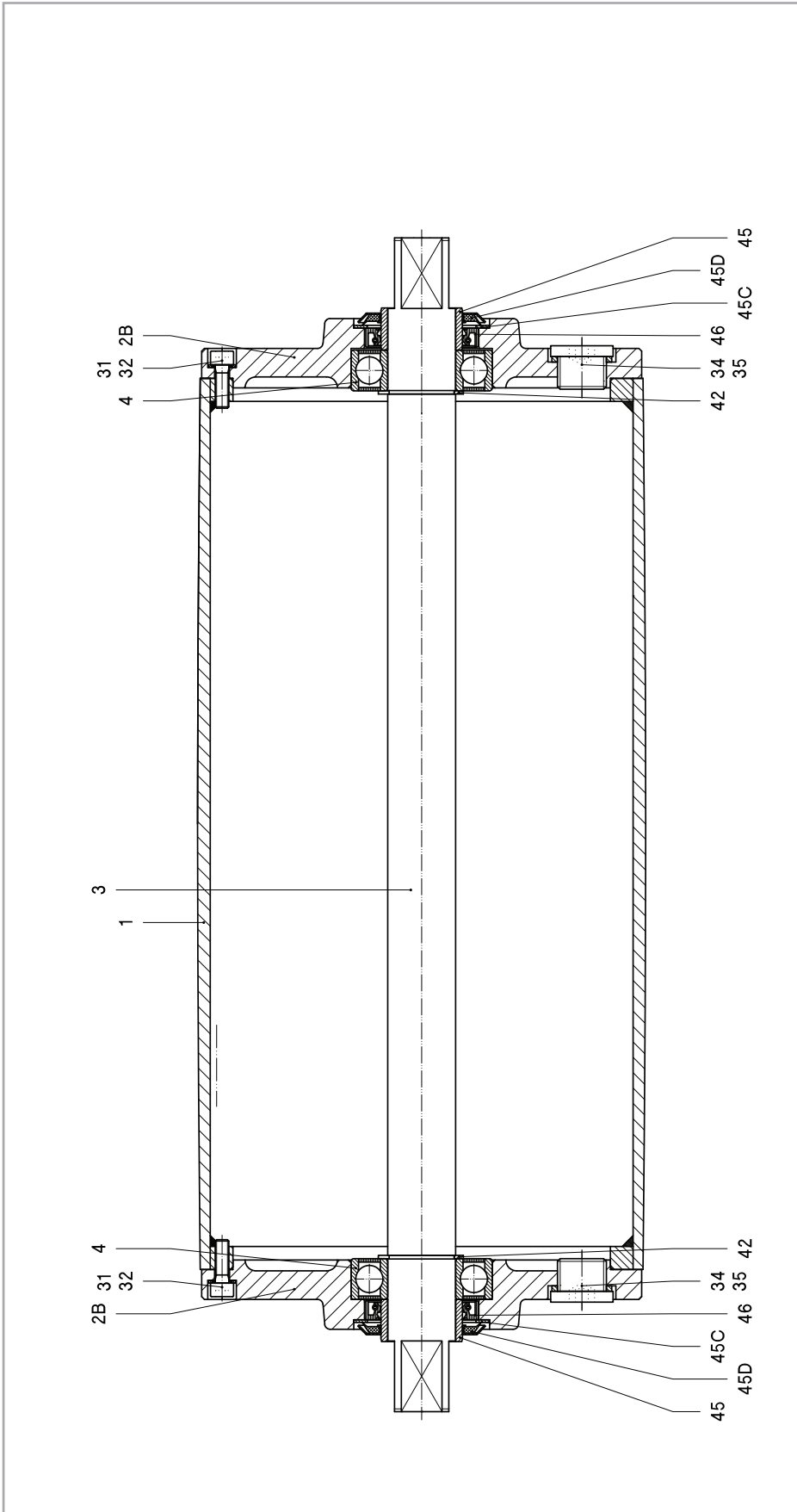

Remark: Taildrum also available in B-design (KT1 60B25)

1	Shell	35	Washer
2B	Endflange	42	Circlip
3	Shaft	45	Bearing race
4	Ballbearing	45C	Shim plated
31	Int. hex screw	45D	Gammaring
32	Washer	46	Oilseal
34	Filler plug		



## Material

The external parts of the Drummotor are made from mild steel and cast iron. Depending on the application it is also possible to manufacture in stainless steel (complete or part). You can choose between stainless steel 304 (general food industry) and stainless steel 316 (salt water applications).

## Backstop - Brake

If an inclined belt conveyor is stopped fully loaded, it could run backwards.

To prevent this we can install a backstop. One of the bearings in the Drummotor is replaced by a one way bearing. The way this bearing is installed determines the direction of rotation of the drum. TBRH indicates a cw rotation and TBLH ccw.

In situations where a Drummotor needs to be able to drive in both directions it is not possible to use a backstop. In this case we use a brake. When an declined belt or a horizontal belt needs to be stopped quickly to pick or place items a brake is the best solution.

## Inclined position

Sometimes a Drummotor needs to be installed on an inclined or even vertical position. This is possible, but we need to make adjustments to the oil level in the drum as the oil will flow to the lower side of the Drummotor causing the top bearing to run without lubrication. To prevent problems we will need to know the installation angle so we can fill the drum with extra oil and fit a double sealed bearing on the upper side.

## Thermal protection

A Van der Graaf Drummotor can be fitted with thermal protection. This consists of either a thermistor (PTC) or bi-metal (klixon). We install these on each phase of the electric motor.

## Encoder - Sensor bearing

In certain applications it is required to measure the speed or position of a conveyor belt. For this type of application we can install an encoder or sensor bearing to accurately measure rotational speed of the Drummotor.

The accuracy needed will determine the type of encoder or sensor used.

## Lagging

The power produced by the Drummotor has to be transferred to the belt and lagging is used to give more friction between the Drummotor and the conveyor belt. Van der Graaf can fit your Drummotor with different kinds of lagging.

There is a difference between cold and hot vulcanised lagging. Cold vulcanised means the lagging is glued to the Drummotor usually in sheet form and the join 'welded' together. Hot vulcanising is a process where the shell is wrapped around with thin layers of rubber. The shell with the rubber is then baked in an autoclave fusing the layers together creating a seamless finish.

It is possible to cut grooves (e.g chevron or diamond) in the lagging.

## Sprockets

Do you wish to use a Drummotor to drive modular belts? Van der Graaf can help you! Fitting sprockets suitable for various types of modular belts is a simple solution. The Drummotor is manufactured with a cylindrical shell and machined with a patented 'keying' system. The sprockets are simply 'slid' on and locked securely into position.

## Sealings for mild steel Drummotors

RB sealing - IP 66



This is Van der Graaf's standard sealing. This type of sealing will work in most conditions.

RBS sealing - IP 66



This sealing is specifically designed for those applications where high water pressure is used for cleaning.

HD sealing - IP 66



This sealing is designed for abrasive applications, like sand, gravel and soil.

## Sealings for stainless steel Drummotors

CR sealing - IP 66



This is our standard sealing for stainless steel Drummotors, a very effective, multi labyrinth sealing.

UW sealing - IP 68



This sealing is suitable for under water applications. The maximum depth is approx 2,5 m.





# Options

Specification	Standard	Optional
<b>Construction</b>		
Shafts and bolts	Mild steel	Stainless steel
Endflanges	Cast iron	Stainless steel
Shell	Mild steel	Stainless steel
Junctionbox	Cast iron	Stainless steel or polyamide
Cable		Shielded or non-shielded
Sealing mild steel	RB	RBS, HD
Sealing stainless steel	CR	UW
<b>Shell</b>		
Crowned	•	
Cylindrical		•
Balanced		•
Lagging, cold vulcanised		•
Lagging, hot vulcanised		•
Lagging, FDA approved		•
Fitted with grooves, patterns		•
Sprockets		•
<b>Electro motor</b>		
Three-phase asynchronous	•	
Power supply	230/400 V - 50 Hz	Other voltages and frequencies on request
Two speed (Dahlander)		•
Insulation class	F	H
Thermal protection		Bi-metal or thermistor
Run by frequency inverter	•	
<b>Other options</b>		
Food grade oil		•
Backstop, mechanical		•
Brake, electro mechanical		•
Clutch brake, electro mechanical		•
Inclined or vertical position		•
Other facewidth's		•
Different shaft designs		•
Encoder or sensor bearing in Drummotor		•
Encoder or sensor bearing in Taildrum		•
<b>Certificates</b>		
CE	•	
UL		•
CSA		•
ATEX zone 22, dust		•
UW Under water application (IP68)		•

# Product range

## Our products, an overview

Drum motor type	TM 100B25	TM 113B25	TM 127.25	TM 138.25	TM 160.25	TM 160.30	TM 215.30	TM 215.40
Drum diameter (mm)	100	113	127	138	160	160	215	215
Shaft diameter (mm)	25	25	25	25	25	30	30	40
Power (kW)	0.05-0.37	0.04-0.55	0.10-1.1	0.10-1.1	0.10-0.75	0.10-2.2	0.10-2.2	0.37-5.5
Speed (m/s)	0.007-3.60	0.008-4.40	0.008-2.60	0.009-2.80	0.13-3.30	0.06-4.00	0.08-5.30	0.12-4.70

Drum motor type	TM 215B50	TM 273.40	TM 315.40	TM 315.50	TM 400.50	TM 400.60	TM 500.60	TM 500A75
Drum diameter (mm)	215	273	315	315	400	400	500	500
Shaft diameter (mm)	50	40	40	50	50	60	60	75
Power (kW)	1.5-4.0	0.37-5.5	0.37-5.5	1.1-11	1.1-11	1.5-22	1.5-22	11-30
Speed (m/s)	0.18-0.31	0.16-4.95	0.18-5.20	0.16-4.40	0.20-4.80	0.20-4.60	0.25-4.70	0.80-3.20

Drum motor type	TM 620A75	TM 630A100	TM 800A100	TM 800A130
Drum diameter (mm)	620	630	800	800
Shaft diameter (mm)	75	100	100	130
Power (kW)	11-30	22-55	22-55	55-132
Speed (m/s)	1.00-3.90	1.00-4.00	1.25-5.10	1.60-4.50



### Design benefits

- Robust, industrial design
- Fully enclosed
- Oil filled
- Well-sized gears and bearings

### Installation advantages

- Easy to install
- Compact and reliable
- Easy to clean
- Virtually maintenance free
- Low Life Cycle Costs



# Notes

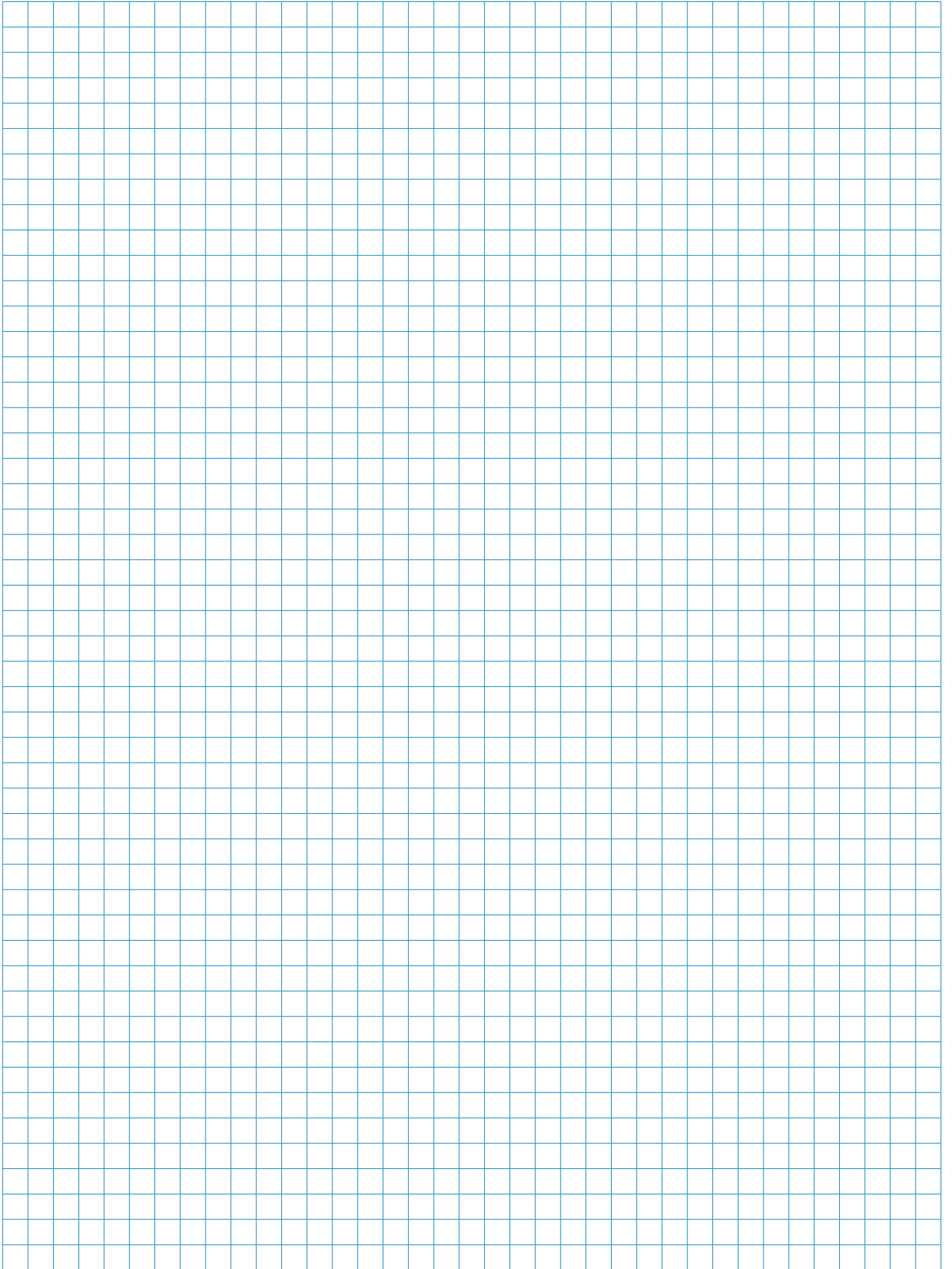



# Van der Graaf

## Power Transmission Equipment

### Contact us

#### Netherlands

Van der Graaf B.V.  
De Weijert 14  
P.O. Box 3  
8325 ZG Vollenhove  
Tel: 00 31 527 241441  
Fax: 00 31 527 241488  
E-mail: [info@vandergraafpte.nl](mailto:info@vandergraafpte.nl)  
[www.vandergraafpte.nl](http://www.vandergraafpte.nl)



#### Canada

Van der Graaf Inc.  
2 Van der Graaf Court  
Brampton  
Ontario L6T 5R6  
Tel: 00 1 905 793 8100  
Fax: 00 1 905 793 812  
E-mail: [info@vandergraaf.com](mailto:info@vandergraaf.com)  
[www.vandergraaf.com](http://www.vandergraaf.com)



#### Great Britain

Van der Graaf U.K. Ltd.  
Unit 23, The Metro Centre  
Welbeck Way Woodston  
Peterborough PE2 7UH  
Tel: 00 44 1733 391777  
Fax: 00 44 1733 391044  
E-mail: [sales@vandergraaf.co.uk](mailto:sales@vandergraaf.co.uk)  
[www.drummy.com](http://www.drummy.com)



#### USA

Van der Graaf Corp.  
51515 Celeste  
Shelby Township  
48315 Michigan  
Tel: 00 1 866 595 3292  
Fax: 00 1 888 326 0089



#### Germany

Van der Graaf GmbH  
Rheiner Straße 24 B  
48432 Rheine-Mesum  
Tel: 00 49 5975 306210  
Fax: 00 49 5975 3062120  
E-mail: [info@vandergraaf.de](mailto:info@vandergraaf.de)  
[www.vandergraaf.de](http://www.vandergraaf.de)



#### Sweden

Van der Graaf Scandinavia AB  
Spinngatan 2  
267 73 Billesholm  
Tel: 00 46 42 22 0802  
Fax: 00 46 42 22 0803  
E-mail: [info@vandergraaf.se](mailto:info@vandergraaf.se)  
[www.vandergraaf.se](http://www.vandergraaf.se)



#### Finland

Van der Graaf Scandinavia AB  
Tel: 00 358 400 419063  
E-mail: [info@vandergraaf.fi](mailto:info@vandergraaf.fi)  
[www.vandergraaf.fi](http://www.vandergraaf.fi)